Using the SMVector in a Package Filler Application

Concept:

The customer manufactures products of different sizes and shapes and therefore uses different size packing boxes for their products. They would like to automatically control the flow of filler material in the packing boxes to ensure maximum protection during transportation.

The filler material is a relatively dense foam pellet. The pellets are stored in a large vessel and are delivered via an auger to the filler head. The SMVector drive is controlling the speed of the pellet delivery auger.

The filler head is an inverted conical shape and contains limit switches to provide feedback to the SMVector with regards to the level of filler material present in the filler head. At the bottom of the filler head is a butterfly type valve the controls the flow of the filler pellets into the packages. The butterfly valve is controlled by sensors that detect if a package is present for filling or not.

Typical Operation:

1. The sensors for detecting packages are always active.
 - a. If the sensors do not detect packages then the butterfly valve on the bottom of the filler head remains closed and the SMVector and pellet delivery auger are in STOP mode.
 - b. When the sensors detect a package for filling they will actuate the butterfly valve on the filler head to start the flow of material into the package and also provide a start command to the SMVector via switch SW1 to drive the auger.
2. The material that is in the filler head will immediately dispense into the package when the valve is opened.
3. The SMVector and auger will drive material through the filler head and into the package at a preset speed of 60 Hz.
4. As the package becomes full the filler material will start to back up in the filler head.
5. The 3 limit switches in the filler head will provide signals to the SMVector to reduce speed using programmed sequencer segments present in the SMV software.
 - a. When the 1st limit switch (LS1) is reached, the SMVector will begin sequencer segment #1 - the speed is decreased to 47 Hz for 5 seconds (or until the second limit switch is reached) and the SMVector relay output triggers the butterfly valve to close.
 - b. When the 2nd limit switch (LS2) is reached, the SMVector will begin sequencer segment #2 - the speed is decreased to 33 Hz for 5 seconds (or until the 3rd limit switch is reached).
 - c. When the 3rd limit switch (LS3) is reached, the SMVector will begin sequencer segment #3 - the speed is reduced to 17 Hz for 10 seconds.
 - d. After sequence segment #3, the SMVector will go into STOP mode and await the next package.

Figures 1 and 2 contain a block diagram of the application and the wiring diagram of the SMVector drive. A description of the SMVector parameter settings is included after the figures. Consult the SMVector Frequency Inverter Operating Instructions (SV01) for more details on programming the SMVector parameters.

Block and Wiring Diagrams:

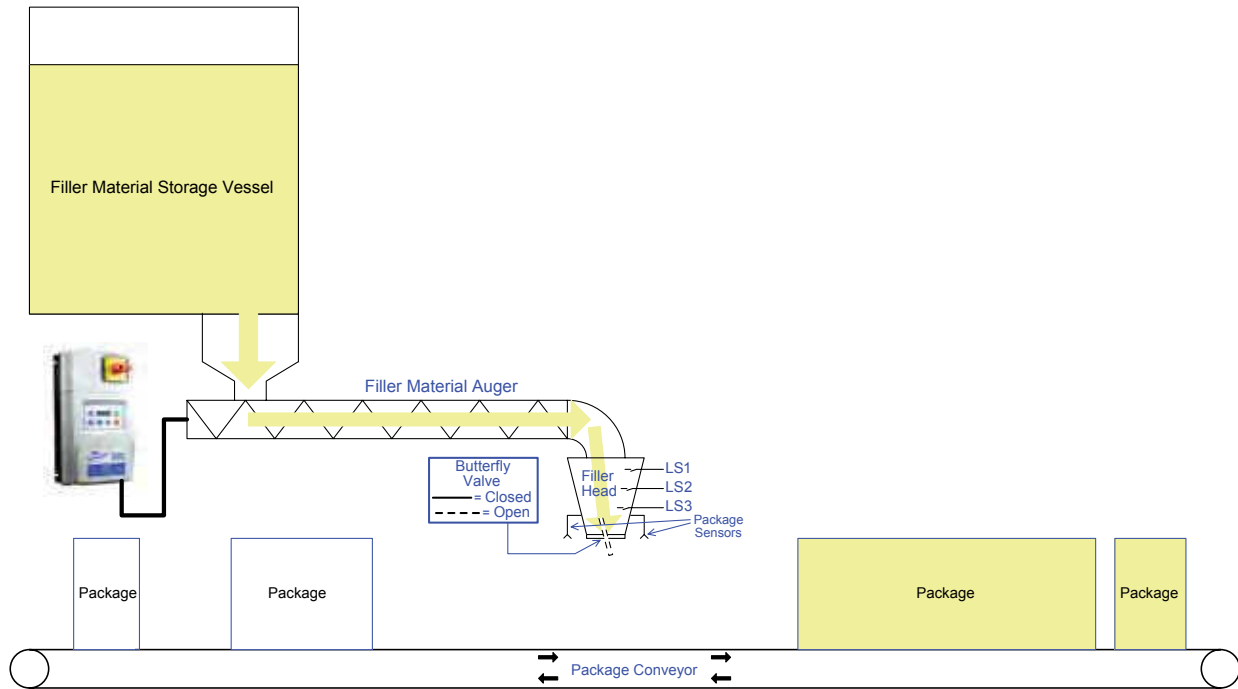

Figure 1: Package Filler Block Diagram

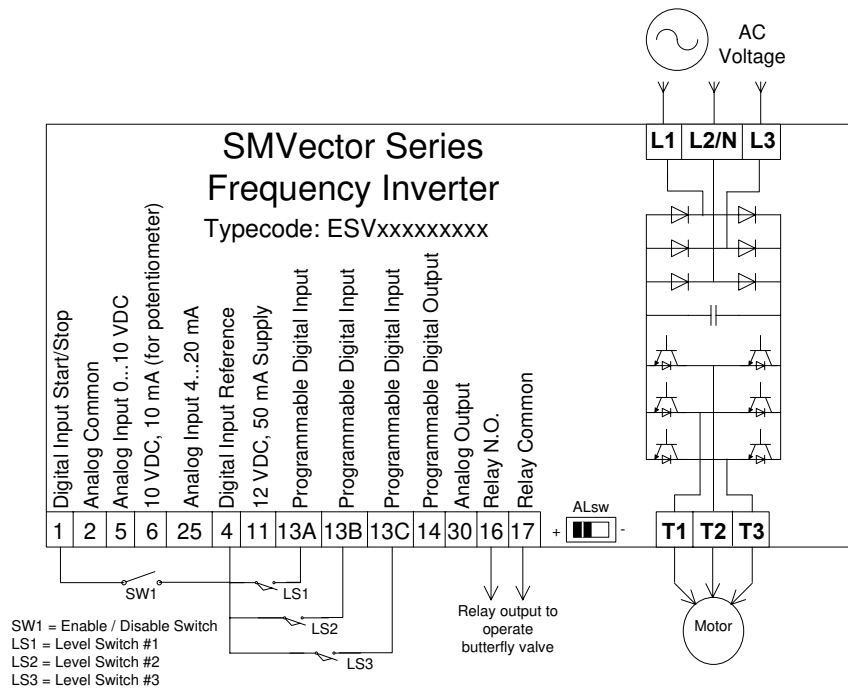

Figure 2: SMVector Wiring Diagram

SMVector Parameter Settings:



NOTE:

For this filler application, only the parameters listed below were changed. All other parameters were left at factory default settings.

Parameters are designated by “P”. Please consult the SMVector Frequency Inverter Operating Instructions (SV01) for more details on programming the SMVector parameters.

- P100 (Start Control Source) = 1 this allows the SMVector to accept START / STOP commands from a switch wired to the terminal strip (SW1 in this example). When SW1 is closed the SMVector will START; when SW1 is open the SMVector will STOP. (note – the red STOP key on the keypad will always stop the drive also).
- P101 (Standard Speed Source) = 3 this sets the default speed source for PRESET SPEED #1. This is the speed that the SMVector will run at when no other speed references are selected. In this example we will set the PRESET SPEED #1 value at 60.0 Hz (see parameter # 131 below).
- P104 (Acceleration Time) = 1.0 this sets the acceleration time at 1.0 second for this example. This is the time it will take to get from 0.0 Hz to full speed 60.0 Hz. (note – to accelerate to 30.0 Hz (half speed) will only take 0.5 seconds (half of the programmed time).
- P105 (Deceleration Time) = 1.0 this sets the deceleration time at 1.0 second for this example. This is the time it will take to get from 60.0 Hz full speed down to 0.0 Hz. (note – to decelerate to 30.0 Hz (half speed) will only take 0.5 seconds (half of the programmed time).
- P111 (Stop Method) = 2 this sets the drive to ramp to a stop following the deceleration time programming in P105 above
- P121 (TB-13A Digital Input) = 23 this sets terminal # 13A to select Sequencer segment #1 when it is asserted. In this example terminal 13A will be asserted when limit switch #1 (LS1) closes. You’ll see below how we setup sequence segment #1 for the speed and time we want for this example.
- P122 (TB-13B Digital Input) = 23 this sets terminal # 13B to select Sequencer segment #2 when it is asserted. In this example terminal 13B will be asserted when limit switch #2 (LS2) closes. You’ll see below how we setup sequence segment #2 for the speed and time we want for this example.
- P123 (TB-13C Digital Input) = 23 this sets terminal # 13C to select Sequencer segment #3 when it is asserted. In this example terminal 13C will be asserted when limit switch #3 (LS3) closes. You’ll see below how we setup sequence segment #3 for the speed and time we want for this example.

- P131 (Preset Speed #1) = 60.0 this set the PRESET SPEED #1 value at 60.0 Hz. This is the speed the SMVector will run at when no other speed reference is selected (see P101). When other speed references are selected by using terminals 13A, B or C, the PRESET SPEED #1 will be ignored and the selected speed reference will have priority.
- P140 (Relay Output) = 27 This allows the SMVector relay output to be controlled by the sequencer segments. In this example we'll activate the relay output in sequencer segment #1 to trigger the butterfly valve on the filler dear to close.
- P700 (Sequencer Mode) = 3 this sets the SMVector sequence mode to work in a "Timed" and "Step" mode concurrently. In our example we have 3 sequencer segments each with a speed and time. If the SMVector is in the 1st segment (activated by asserting terminal 13A) and it doesn't receive any additional inputs, then it will run at the segment #1 programmed speed for the specified time then stop. If we receive a command from 13B or 13C then we'll immediately go to that segment and execute that programmed speed and time. So, in this mode the SMVector will follow the time of the segment unless it is told to "step" to the next segment by asserting another digital input.
- P701 (Sequencer: Trigger TB-13A Segment) = 1 this defines the segment of the sequence that will be active when terminal TB-13A is asserted.
- P702 (Sequencer: Trigger TB-13B Segment) = 2 this defines the segment of the sequence that will be active when terminal TB-13B is asserted.
- P703 (Sequencer: Trigger TB-13C Segment) = 3 this defines the segment of the sequence that will be active when terminal TB-13C is asserted.
- P710 (Segment #1 Frequency Setpoint) = 47.0 this sets the segment #1 speed to 47.0 Hz.
- P711 (Segment #1 Accel / Decel Time) = 1.0 this sets the time of acceleration and deceleration into segment #1 at 1.0 seconds.
- P712 (Segment #1: Time in Current Step) = 5.0 this sets the time that the SMVector will run at the speed set in P711.
- P713 (Segment #1: Digital Output State) = 1 this sets up the relay output to be active when the SMVector is in sequencer segment #1. In this example we are using the relay to trigger the butterfly valve to close.
- P715 (Segment #2 Frequency Setpoint) = 33.0 this sets the segment #2 speed to 33.0 Hz.
- P716 (Segment #2 Accel / Decel Time) = 1.0 this sets the time of acceleration and deceleration into segment #2 at 1.0 seconds.

P717 (Segment #2: Time in Current Step) = 5.0	this sets the time that the SMVector will run at the speed set in P715.
P720 (Segment #3 Frequency Setpoint) = 17.0	this sets the segment #3 speed to 17.0 Hz.
P721 (Segment #3 Accel / Decel Time) = 1.0	this sets the time of acceleration and deceleration into segment #3 at 1.0 seconds.
P722 (Segment #3: Time in Current Step) = 5.0	this sets the time that the SMVector will run at the speed set in P720.
P795 (End segment: Drive Action) = 1	this sets the SMVector to stop after it has completed the last selected sequence segment. A re-assertion of the start command is necessary to restart.

Summary:

The package filling system operates as described in the “Typical Operation” description above. The sequencer segment speeds and times have a wide range of adjustment and can be optimized for other filling materials and applications.

Using the standard SMVector frequency inverter which includes sequencing capabilities and a few inexpensive limit switches and sensors we were able to solve an application for our customer that minimized their control wiring, eliminated the need for an external logic controller or small PLC, simplified their commissioning and support activities and overall reduced their costs.

For more information regarding the SMVector frequency inverter and all our other drive and automation products, please visit our website: www.lenzeamericas.com.