

# Product datasheet

Specifications



## Soft starter, Altistart 480, 32A, 208 to 690V AC, control supply 110 to 230V AC

ATS480D32Y

### Main

<b>Range Of Product</b>	Altivar Soft Starter ATS480
<b>Product Or Component Type</b>	Soft starter
<b>Product Destination</b>	Asynchronous motors
<b>Product Specific Application</b>	Process and infrastructures
<b>Device Short Name</b>	ATS480
<b>Network Number Of Phases</b>	3 phases
<b>Utilisation Category</b>	AC-3A AC-53A
<b>Ue Power Supply Voltage</b>	208...690 V - 15...10 %
<b>Power Supply Frequency</b>	50...60 Hz - 20...20 %
<b>[Ie] Rated Operational Current</b>	Normal duty: 32.0 A (at <40 °C)
<b>Rated Current In Heavy Duty</b>	22.0 A at 40 °C for heavy duty
<b>Torque Control</b>	True
<b>Ip Degree Of Protection</b>	IP20
<b>Motor Power Kw</b>	7.5 kW at 230 V in the motor supply line normal duty 5.5 kW at 230 V in the motor supply line heavy duty 15.0 kW at 400 V in the motor supply line normal duty 11.0 kW at 400 V in the motor supply line heavy duty 15.0 kW at 440 V in the motor supply line normal duty 11.0 kW at 440 V in the motor supply line heavy duty 18.5 kW at 500 V in the motor supply line normal duty 11.0 kW at 500 V in the motor supply line heavy duty 18.5 kW at 525 V in the motor supply line normal duty 11.0 kW at 525 V in the motor supply line heavy duty 22.0 kW at 660 V in the motor supply line normal duty 15.0 kW at 660 V in the motor supply line heavy duty 22.0 kW at 690 V in the motor supply line normal duty 18.5 kW at 690 V in the motor supply line heavy duty 15.0 kW at 230 V to the motor delta terminals normal duty 9.0 kW at 230 V to the motor delta terminals heavy duty 22.0 kW at 400 V to the motor delta terminals normal duty 18.5 kW at 400 V to the motor delta terminals heavy duty
<b>Motor Power Hp</b>	7.5 hp at 208 V normal duty 5.0 hp at 208 V heavy duty 10.0 hp at 230 V normal duty 7.5 hp at 230 V heavy duty 20.0 hp at 460 V normal duty 15.0 hp at 460 V heavy duty 25.0 hp at 575 V normal duty 20.0 hp at 575 V heavy duty

<b>Option Card</b>	Communication module for Profibus DP V1 Communication module for PROFINET Communication module for Modbus TCP/EtherNet/IP Communication module for CANopen daisy chain Communication module for CANopen Sub-D Communication module for CANopen open style
--------------------	--

## Complementary

<b>Device Connection</b>	In the motor supply line To the motor delta terminals
<b>[Us] Control Circuit Voltage</b>	110...250 V AC 50/60 Hz - 15...10 %
<b>Apparent Power</b>	0.09 kVA
<b>Integrated Motor Overload Protection</b>	True
<b>Motor Thermal Protection Class</b>	Class 10E
<b>Protection Type</b>	Phase failure: line Integrated thermal protection: motor Thermal protection: starter Current overload: motor Underload: motor Excessive starting time, locked rotor: motor Motor phase loss: motor Line supply phase loss: line Line supply phase loss: motor Thermal protection: motor
<b>Current Limiting %In (5 X Ie Maximum)</b>	150...700 %
<b>Rated Current Pwr Loss Specification</b>	32.0 A
<b>Power Loss Static Current Independent</b>	25.0 W
<b>Power Loss Per Device Current Dependent</b>	84.0 W
<b>Standards</b>	IEC 60947-4-2 UL 60947-4-2 IEC 60664-1
<b>Product Certifications</b>	CE cULus CCC UKCA RCM EAC DNV ABS BV CCS
<b>Marking</b>	CE CCC UKCA EAC RCM CULus
<b>[Uc] Control Circuit Voltage</b>	24 V DC
<b>Discrete Input Number</b>	4
<b>Discrete Input Type</b>	(STOP) logic inputs, 3500 Ohm (RUN) logic inputs, 3500 Ohm (DI3) programmable as logic input, 3500 Ohm (DI4) programmable as logic input, 3500 Ohm
<b>Input Compatibility</b>	STOP: discrete input level 1 PLC conforming to IEC 61131-2 RUN: discrete input level 1 PLC conforming to IEC 61131-2 DI3: discrete input level 1 PLC conforming to IEC 61131-2 DI4: discrete input level 1 PLC conforming to IEC 61131-2
<b>Discrete Input Logic</b>	Programmable digital input at State 0: < 5 V
<b>Relay Output Number</b>	3
<b>Relay Output Type</b>	Relay outputs R1A 1 NO Relay outputs R1B 1 NO Relay outputs RIC NO/NC programmable
<b>Minimum Switching Current</b>	100 mA at 12 V DC for relay outputs

<b>Maximum Switching Current</b>	Relay outputs 2 A at 250 V AC Relay outputs 2 A at 30 V DC
<b>Discrete Output Number</b>	2
<b>Discrete Output Type</b>	(DQ1) programmable digital output <= 30 V (DQ2) programmable digital output <= 30 V
<b>Output Compatibility</b>	Open collector level 1 PLC conforming to IEC 65A-68
<b>Analogue Input Number</b>	1
<b>Analogue Input Type</b>	AI1/PTC PTC/Pt 100 temperature probe PTC2 PTC/Pt 100 temperature probe PTC3 PTC/Pt 100 temperature probe
<b>Analogue Output Number</b>	1
<b>Analogue Output Type</b>	Current output AQ1: 0...20 mA or 0...10 V, impedance <500 Ohm
<b>Communication Port Protocol</b>	Modbus serial
<b>Connector Type</b>	1 RJ45
<b>Communication Data Link</b>	Serial
<b>Physical Interface</b>	2-wire RS 485
<b>Transmission Rate</b>	1200...256000 bit/s
<b>Transmission Frame</b>	RTU
<b>Data Format</b>	8 bits, configurable odd, even or no parity
<b>Type Of Polarization</b>	No impedance for Modbus serial
<b>Number Of Addresses</b>	0...227 for Modbus serial
<b>Method Of Access</b>	Slave Modbus serial
<b>Function Available</b>	External bypass control Pre-heating Smoke extraction Multi-motor cascade Second motor set User management Ports and services hardening Security event logging Cybersecure firmware update Single direction
<b>Display Screen Available</b>	True
<b>Operating Position</b>	Vertical +/- 10 degree
<b>Height</b>	275.0 mm
<b>Width</b>	160.0 mm
<b>Depth</b>	203.0 mm
<b>Net Weight</b>	4.9 kg

## Environment

<b>Electromagnetic Compatibility</b>	Conducted and radiated emissions level A conforming to IEC 60947-4-2 Conducted and radiated emissions with bypass level B conforming to IEC 60947-4-2 Damped oscillating waves level 3 conforming to IEC 61000-4-12 Electrostatic discharge level 3 conforming to IEC 61000-4-11 Immunity to electrical transients level 4 conforming to IEC 61000-4-4 Immunity to radiated radio-electrical interference level 3 conforming to IEC 61000-4-3 Voltage/current impulse level 3 conforming to IEC 61000-4-5
<b>Pollution Degree</b>	Level 3
<b>[Uimp] Rated Impulse Withstand Voltage</b>	6 kV
<b>[Ui] Rated Insulation Voltage</b>	690 V

<b>Environmental Class (During Operation)</b>	Class 3C3 according to IEC 60721-3-3 Class 3S2 according to IEC 60721-3-3
<b>Relative Humidity</b>	0...95 % without condensation or dripping water conforming to IEC 60068-2-3
<b>Ambient Air Temperature For Operation</b>	40...60 °C (with current derating of 2 % per °C) -15...40 °C (without derating)
<b>Ambient Air Temperature For Storage</b>	-25...70 °C
<b>Operating Altitude</b>	<= 1000 m without derating > 1000...4000 m with current derating 1 % per 100 m
<b>Maximum Deflection Under Vibratory Load (During Operation)</b>	1.5 mm at 2...13 Hz
<b>Maximum Deflection Under Vibratory Load (During Storage)</b>	1.75 mm at 2...9 Hz
<b>Maximum Deflection Under Vibratory Load (During Transport)</b>	1.75 mm at 2...9 Hz
<b>Maximum Acceleration Under Vibrational Stress (During Operation)</b>	10 m/s <sup>2</sup> at 13...200 Hz
<b>Maximum Acceleration Under Vibratory Load (During Storage)</b>	15 m/s <sup>2</sup> at 200...500 Hz 10 m/s <sup>2</sup> at 9...200 Hz
<b>Maximum Acceleration Under Vibratory Load (During Transport)</b>	15 m/s <sup>2</sup> at 200...500 Hz 10 m/s <sup>2</sup> at 9...200 Hz
<b>Maximum Acceleration Under Shock Impact (During Operation)</b>	150 m/s <sup>2</sup> at 11 ms
<b>Maximum Acceleration Under Shock Load (During Storage)</b>	100 m/s <sup>2</sup> at 11 ms
<b>Maximum Acceleration Under Shock Load (During Transport)</b>	100 m/s <sup>2</sup> at 11 ms

## Packing Units

<b>Unit Type Of Package 1</b>	PCE
<b>Number Of Units In Package 1</b>	1
<b>Package 1 Height</b>	30.000 cm
<b>Package 1 Width</b>	28.000 cm
<b>Package 1 Length</b>	37.000 cm
<b>Package 1 Weight</b>	6.260 kg
<b>Unit Type Of Package 2</b>	P06
<b>Number Of Units In Package 2</b>	8
<b>Package 2 Height</b>	75.000 cm
<b>Package 2 Width</b>	60.000 cm
<b>Package 2 Length</b>	80.000 cm
<b>Package 2 Weight</b>	64.900 kg

## Sustainability

**Green Premium™ label** is Schneider Electric's commitment to delivering products with best-in-class environmental performance. Green Premium promises compliance with the latest regulations, transparency on environmental impacts, as well as circular and low-CO<sub>2</sub> products.

**Guide to assessing product sustainability** is a white paper that clarifies global eco-label standards and how to interpret environmental declarations.

[Learn more about Green Premium >](#)

[Guide to assess a product's sustainability >](#)



Transparency RoHS/REACH

## Resource performance

Upgraded Components Available

## Well-being performance

Mercury Free

Rohs Exemption Information Yes

## Certifications & Standards

Reach Regulation [REACH Declaration](#)

Eu Rohs Directive Pro-active compliance (Product out of EU RoHS legal scope)

China Rohs Regulation [China RoHS declaration](#)

Environmental Disclosure [Product Environmental Profile](#)

Weee The product must be disposed on European Union markets following specific waste collection and never end up in rubbish bins

Circularity Profile [End of Life Information](#)

Dimensions Drawings

Dimensions

---

Front, Side and Rear View

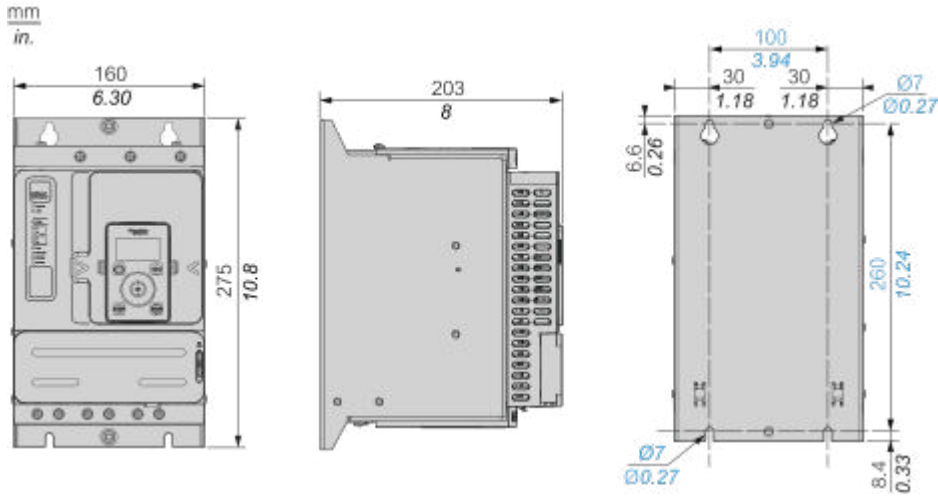

Connections and Schema

Power Connections

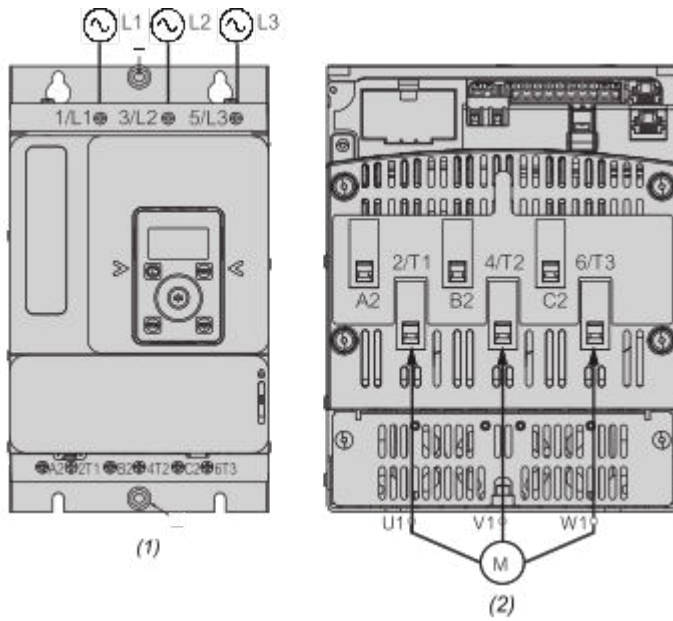

- (1) : Mains side
- (2) : Motor side
- 1/L1, 3/L2, 5/L3 : Mains supply inputs
- 2/T1, 4/T2, 6/T3 : Outputs to motor
- A2, B2, C2 : Soft starter bypass

Connection in line, with line contactor, no bypass, type 1 or 2 coordination, non-reversing, 2-wire or 3-wire control

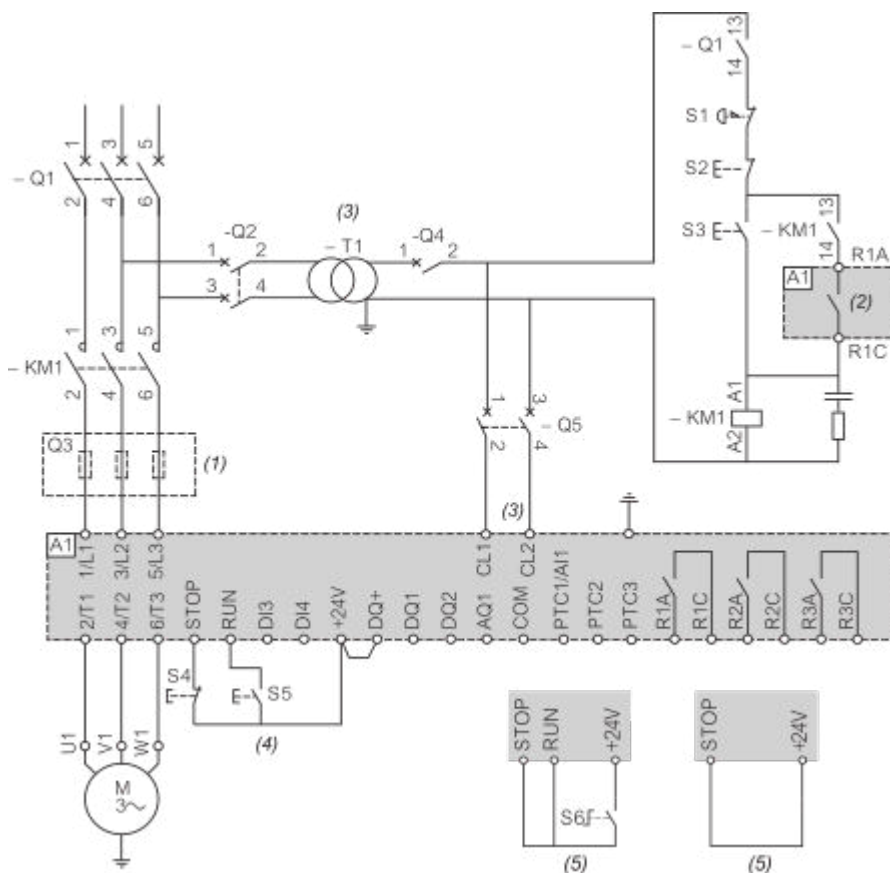

- (1) : Installation of additional fast-acting fuses to upgrade to type 2 coordination according to IEC 60947-4-2.
- (2) : Take into account the electrical characteristics of the relays (Control Terminal Characteristics).
- (3) : The transformer must supply 110...230 VAC +10% — 15%, 50/60Hz.
- (4) : RUN and STOP Management (3-wire control).
- (5) : RUN and STOP Management (2-wire control).

Connection in line, with line and bypass contactor, freewheel or controlled stop, type 1 or 2 coordination, non reversing, 2-wire or 3-wire

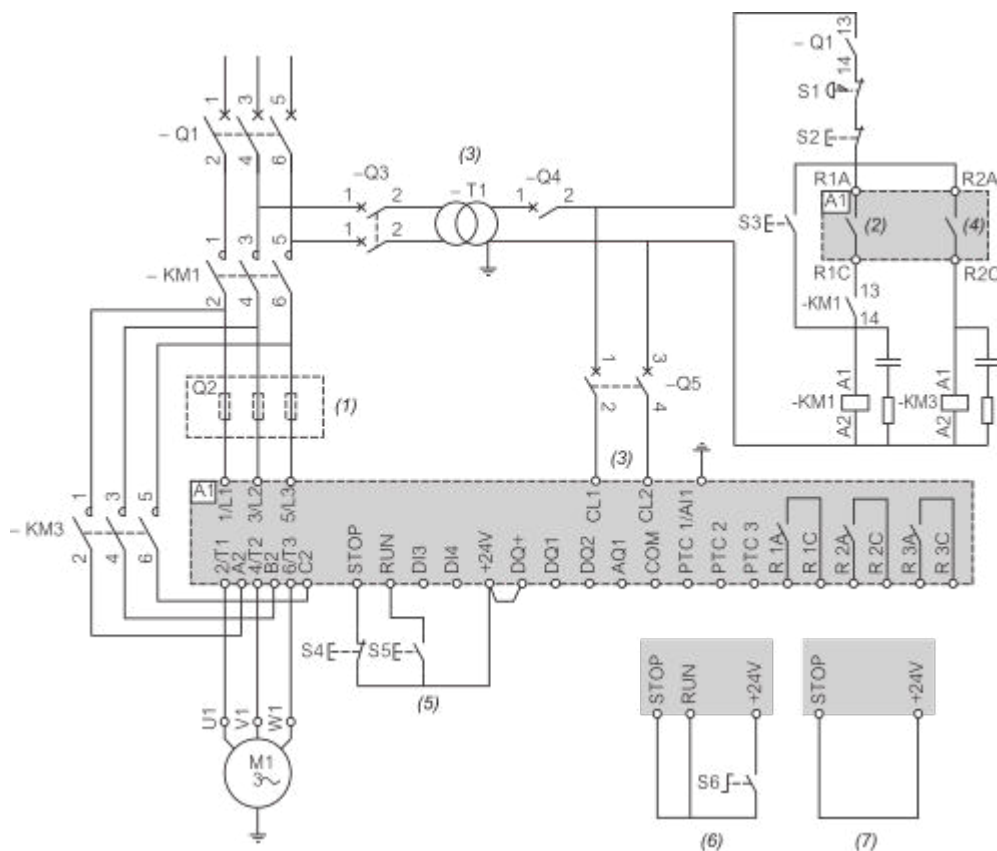

- (1) : Installation of additional fast-acting fuses to upgrade to type 2 coordination according to IEC 60947-4-2.
- (2) : Take into account the electrical characteristics of the relays (Control Terminal Characteristics).
- (3) : The transformer must supply 110...230 VAC +10% - 15%, 50/60Hz.
- (4) : Take into account the electrical characteristics of the relays, especially when connecting to high rating contactor (Control Terminal Characteristics).
- (5) : RUN and STOP Management (3-wire control).
- (6) : RUN and STOP Management (2-wire control).
- (7) : PC or PLC control

Connection inside the delta, with line and bypass contactor, type 1 and 2 coordination, non reversing, 2 wire or 3 wire

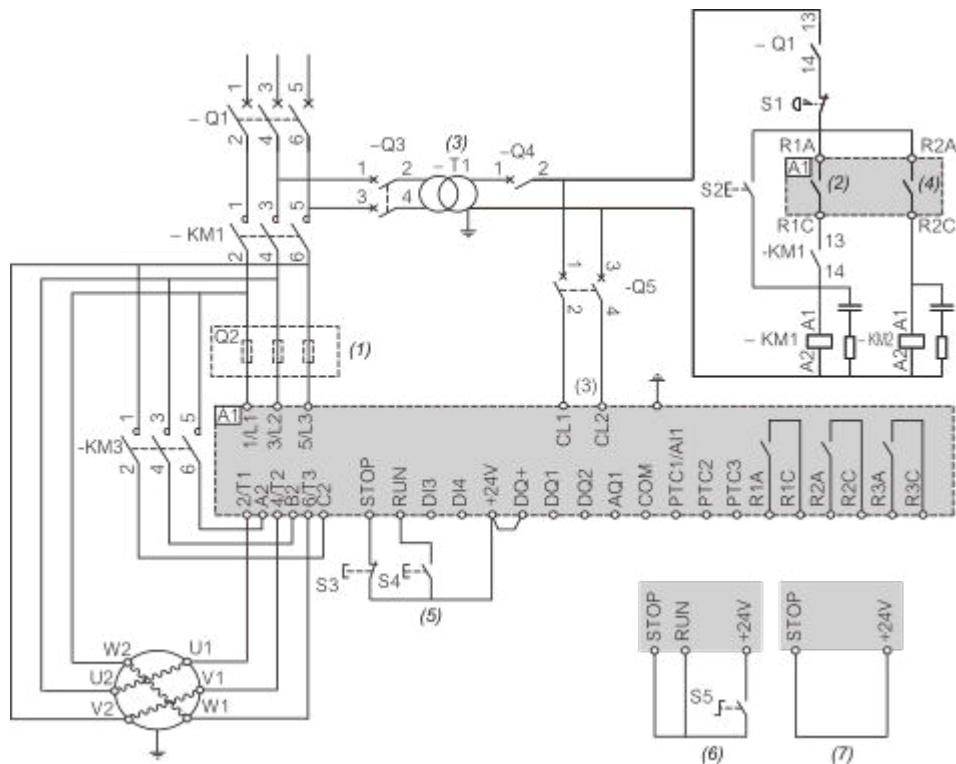

- (1) : Installation of additional fast-acting fuses to upgrade to type 2 coordination according to IEC 60947-4-2.
- (2) : Take into account the electrical characteristics of the relays (Control Terminal Characteristics).
- (3) : The transformer must supply 110...230 VAC +10% – 15%, 50/60Hz.
- (4) : Take into account the electrical characteristics of the relays, especially when connecting to high rating contactor (Control Terminal Characteristics).
- (5) : RUN and STOP Management (3-wire control).
- (6) : RUN and STOP Management (2-wire control).
- (7) : PC or PLC control

Control block wiring diagram

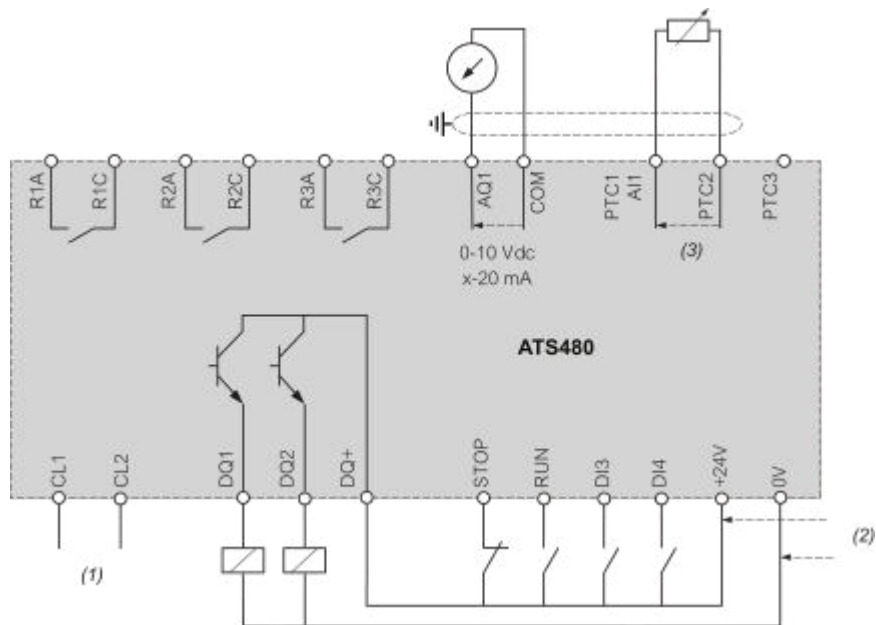

(1) : Control power supply 110-230 VAC

(2) : External supply 24 VDC

(3) : 2 Wires PTC/PT100

R1A, R1C, R3A, R3C : Sequence relay

R2A, R2C : End of start

STOP, RUN, DI3, DI4 : Digital inputs

AQ1 : Analogue output

PTC1/AI1, PTC2, PTC3 : PTC or PT100 connection

DQ1, DQ2, DQ+ : Digital outputs

Mounting and Clearance

Mounting Position

---

mm  
in.

