

# Product data sheet

Specifications



## discrete output module, Modicon TM3, 16 relay outputs, spring, 24V DC

TM3DQ16RG

### Main

Range Of Product	Modicon TM3
Product Or Component Type	Discrete output module
Range Compatibility	Modicon M241 Modicon M251 Modicon M221 Modicon M262
Discrete Output Type	Relay normally open
Discrete Output Number	16
Discrete Output Logic	Positive or negative
Discrete Output Voltage	240 V AC relay output 30 V DC relay output
Discrete Output Current	2000 mA relay output

### Complementary

Discrete I/O Number	16
Current Consumption	0 mA 24 V DC via bus connector at state off) 75 mA 24 V DC via bus connector at state on)
Response Time	10 ms turn-on) 5 ms turn-off)
Mechanical Durability	20000000 cycles
Minimum Load	10 mA 5 V DC relay output
Local Signalling	Output status 1 LED per channel green)
Electrical Connection	10 x 1.5 mm <sup>2</sup> removable spring terminal block pitch 3.81 mm for outputs
Maximum Cable Distance Between Devices	Unshielded cable <98.43 ft (30 m) relay output
Insulation	Between output and internal logic 2300 V AC Between outputs 750 V AC Between output groups 1500 V AC
Marking	CE
Mounting Support	Top hat type TH35-15 rail IEC 60715 Top hat type TH35-7.5 rail IEC 60715 plate or panel with fixing kit
Height	3.54 in (90 mm)
Depth	3.33 in (84.6 mm)
Width	1.08 in (27.4 mm)
Net Weight	0.32 lb(US) (0.145 kg)

## Environment

<b>Standards</b>	IEC 61131-2
<b>Product Certifications</b>	cULus CE UKCA RCM EAC cULus HazLoc
<b>Resistance To Electrostatic Discharge</b>	8 kV in air IEC 61000-4-2 4 kV on contact IEC 61000-4-2
<b>Resistance To Electromagnetic Fields</b>	9.14 V/yd (10 V/m) 80 MHz...1 GHz IEC 61000-4-3 2.74 V/yd (3 V/m) 1.4 GHz...2 GHz IEC 61000-4-3 0.91 V/yd (1 V/m) 2 GHz...3 GHz IEC 61000-4-3
<b>Resistance To Magnetic Fields</b>	98.43 A/ft (30 A/m) 50/60 Hz IEC 61000-4-8
<b>Resistance To Fast Transients</b>	2 kV relay output IEC 61000-4-4
<b>Surge Withstand</b>	1 kV I/O common mode IEC 61000-4-5 DC
<b>Resistance To Conducted Disturbances</b>	10 V 0.15...80 MHz IEC 61000-4-6 3 V spot frequency (2, 3, 4, 6.2, 8.2, 12.6, 16.5, 18.8, 22, 25 MHz) Marine specification (LR, ABS, DNV, GL)
<b>Electromagnetic Emission</b>	Radiated emissions 40 dB $\mu$ V/m QP class A 10 m)30...230 MHz IEC 55011 Radiated emissions 47 dB $\mu$ V/m QP class A 10 m)230...1000 MHz IEC 55011
<b>Ambient Air Temperature For Operation</b>	14...95 °F (-10...35 °C) vertical installation 14...131 °F (-10...55 °C) horizontal installation
<b>Ambient Air Temperature For Storage</b>	-13...158 °F (-25...70 °C)
<b>Relative Humidity</b>	10...95 %, without condensation in operation) 10...95 %, without condensation in storage)
<b>IP Degree Of Protection</b>	IP20 with protective cover in place
<b>Pollution Degree</b>	2
<b>Operating Altitude</b>	0...2000 m
<b>Storage Altitude</b>	0.00...9842.52 ft (0...3000 m)
<b>Vibration Resistance</b>	3.5 mm 5...8.4 Hz DIN rail 3 gn 8.4...150 Hz DIN rail 3.5 mm 5...8.4 Hz panel 3 gn 8.4...150 Hz panel
<b>Shock Resistance</b>	15 gn 11 ms

## Packing Units

<b>Unit Type Of Package 1</b>	PCE
<b>Number Of Units In Package 1</b>	1
<b>Package 1 Height</b>	2.95 in (7.5 cm)
<b>Package 1 Width</b>	4.92 in (12.5 cm)
<b>Package 1 Length</b>	4.13 in (10.5 cm)
<b>Package 1 Weight</b>	8.64 oz (245.0 g)
<b>Unit Type Of Package 2</b>	S04
<b>Number Of Units In Package 2</b>	42
<b>Package 2 Height</b>	11.81 in (30 cm)
<b>Package 2 Width</b>	15.75 in (40 cm)
<b>Package 2 Length</b>	23.62 in (60 cm)
<b>Package 2 Weight</b>	24.85 lb(US) (11.273 kg)

<b>Unit Type Of Package 3</b>	P12
<b>Number Of Units In Package 3</b>	504
<b>Package 3 Height</b>	41.34 in (105 cm)
<b>Package 3 Width</b>	47.24 in (120 cm)
<b>Package 3 Length</b>	31.50 in (80 cm)
<b>Package 3 Weight</b>	319.67 lb(US) (145 kg)

## Sustainability

**Green Premium™ label** is Schneider Electric's commitment to delivering products with best-in-class environmental performance. Green Premium promises compliance with the latest regulations, transparency on environmental impacts, as well as circular and low-CO<sub>2</sub> products.

**Guide to assessing product sustainability** is a white paper that clarifies global eco-label standards and how to interpret environmental declarations.

[Learn more about Green Premium >](#)

[Guide to assess a product's sustainability >](#)



Transparency RoHS/REACH

## Well-being performance

✓ Reach Free Of Svhc

✓ Toxic Heavy Metal Free

✓ Mercury Free

✓ Rohs Exemption Information [Yes](#)

✓ Pvc Free

## Certifications & Standards

**Reach Regulation**

[REACH Declaration](#)

**Eu Rohs Directive**

Pro-active compliance (Product out of EU RoHS legal scope)

[EU RoHS Declaration](#)

**China Rohs Regulation**

[China RoHS declaration](#)

**Environmental Disclosure**

[Product Environmental Profile](#)

**Weee**

The product must be disposed on European Union markets following specific waste collection and never end up in rubbish bins

**Circularity Profile**

[End of Life Information](#)

Dimensions Drawings

Dimensions

---

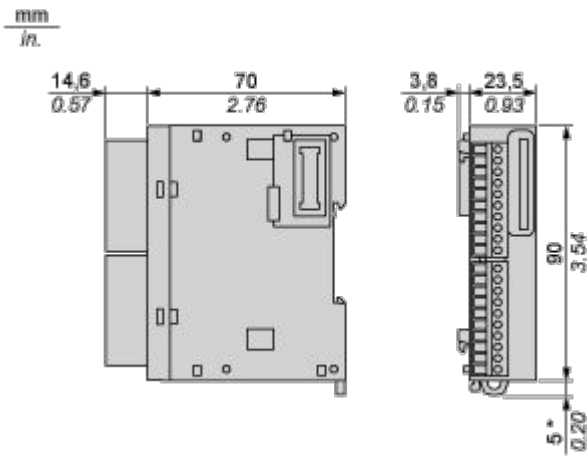

(\*) 8.5 mm/0.33 in. when the clamp is pulled out.

Mounting and Clearance

Spacing Requirements

---

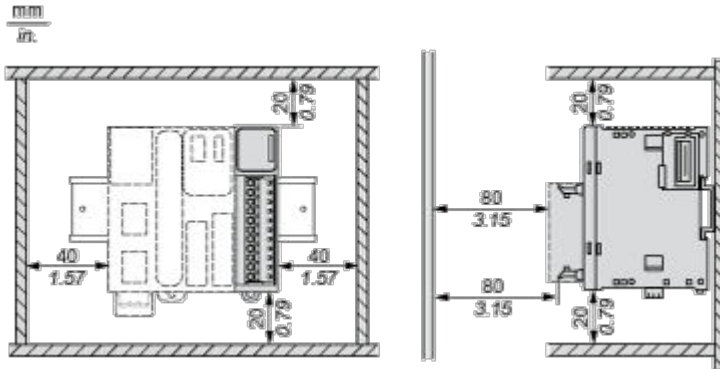

Mounting on a Rail

---

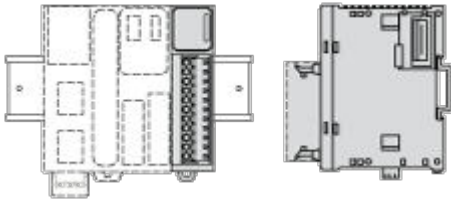

**Incorrect Mounting**

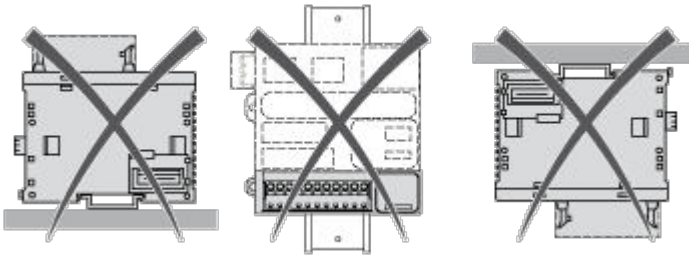

Mounting on a Panel Surface

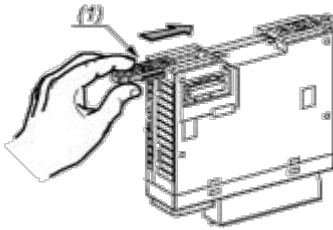

- (1) Install a mounting strip

**Mounting Hole Layout**

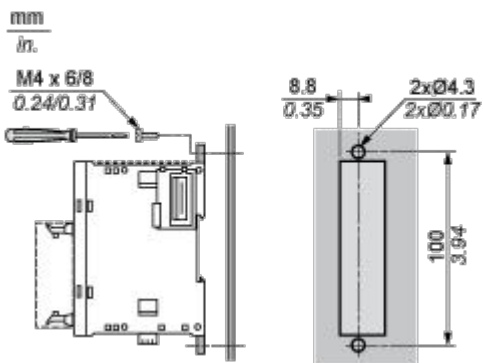

Connections and Schema

Digital Relay Output Module (16-channel)

Wiring Diagram (Positive Logic)

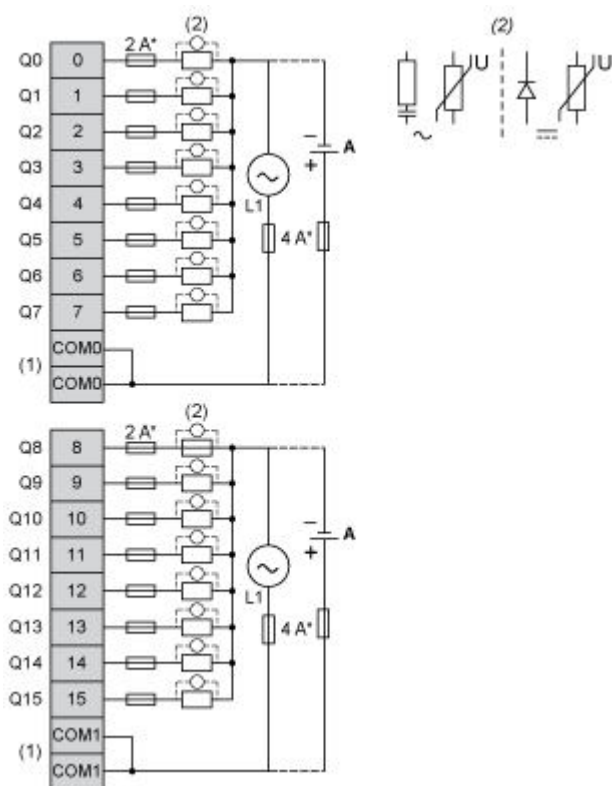

(\* ) Type T fuse

(1) The COM0 and COM1 terminals are **not** connected internally.

(2) To improve the life time of the contacts, and to protect from potential inductive load damage, it is recommended to connect a free wheeling diode in parallel to each inductive DC load or an RC snubber in parallel of each inductive AC load.

(A) Source wiring (positive logic).

Wiring Diagram (Negative Logic)

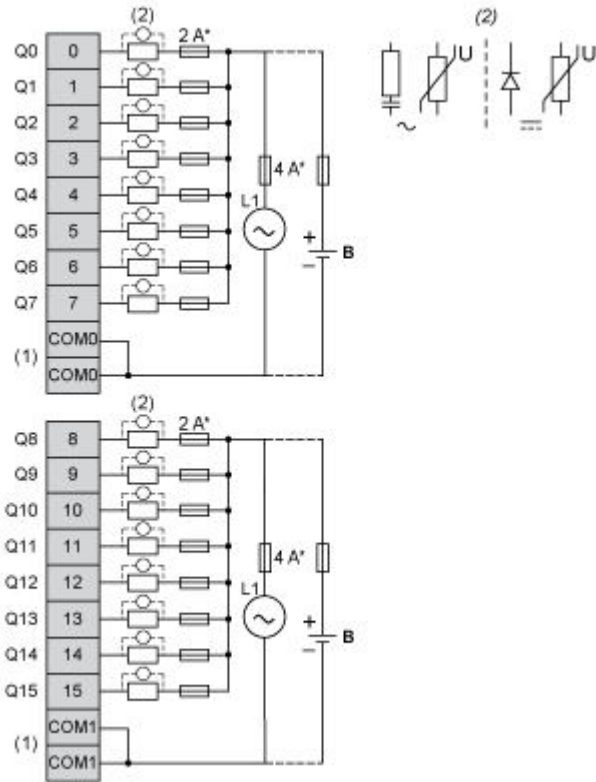

(\*) Type T fuse

(1) The COM0 and COM1 terminals are **not** connected internally.

(2) To improve the life time of the contacts, and to protect from potential inductive load damage, it is recommended to connect a free wheeling diode in parallel to each inductive DC load or an RC snubber in parallel of each inductive AC load.

(B) Sink wiring (negative logic)