

Product data sheet

Specifications



analog IO module, Modicon TM3,
2 analog or temperature inputs, 1
analog output, spring, 24V DC

TM3TM3G

Main

Range Of Product	Modicon TM3
Product Or Component Type	Input/output analog module
Range Compatibility	Modicon M221 Modicon M241 Modicon M251 Modicon M262
Analogue Input Number	2
Analogue Input Type	current 4...20 mA current 0...20 mA voltage 0...10 V voltage - 10...10 V thermocouple - 200...1000 °C thermocouple J thermocouple - 200...1300 °C thermocouple K thermocouple 0...1760 °C thermocouple R thermocouple 0...1760 °C thermocouple S thermocouple 0...1820 °C thermocouple B thermocouple - 200...400 °C thermocouple T thermocouple - 200...1300 °C thermocouple N thermocouple - 200...800 °C thermocouple E thermocouple 0...2315 °C thermocouple C Ni 100/Ni 1000 temperature probe - 60...180 °C Pt 100 temperature probe - 200...850 °C Pt 1000 temperature probe - 200...600 °C
Analogue Output Number	1
Analogue Output Type	Current 4...20 mA Current 0...20 mA Voltage 0...10 V Voltage - 10...10 V

Complementary

Analogue Input Resolution	16 bits 15 bits + sign
Permissible Continuous Overload	13 V voltage 40 mA current
Input Impedance	<= 50 Ohm current >= 1 MOhm voltage >= 1 MOhm thermocouple >= 1 MOhm temperature probe
Analogue Output Resolution	12 bits

Disclaimer: This documentation is not intended as a substitute for and is not to be used for determining suitability or reliability of these products for specific user applications

Lsb Value	0.15 mV 0...10 V voltage 0.30 mV - 10...10 V voltage 0.30 µA 0...20 mA current 0.244 µA 4...20 mA current 0.1 °C temperature probe 0.1 °C thermocouple 2.44 mV 0...10 V voltage 4.88 mV - 10...10 V voltage 4.88 µA 0...20 mA current 3.91 µA 4...20 mA current
Load Type	Resistive
Load Impedance Ohmic	1 kOhm voltage 300 Ohm current
Stabilisation Time	1 ms
Conversion Time	100 ms + 100 ms per channel + 1 controller cycle time thermocouple 100 ms + 100 ms per channel + 1 controller cycle time temperature probe 10 ms + 10 ms per channel + 1 controller cycle time voltage/current
Sampling Duration	10 ms voltage/current 100 ms voltage/current 100 ms thermocouple 100 ms temperature probe
Absolute Accuracy Error	+/- 6 °C at 77 °F (25 °C) for thermocouple R, S 0...200 °C +/- 0.4 % of full scale at 77 °F (25 °C) for thermocouple K - 200...0 °C +/- 0.4 % of full scale at 77 °F (25 °C) for thermocouple J - 200...0 °C +/- 0.4 % of full scale at 77 °F (25 °C) for thermocouple E - 200...0 °C +/- 0.4 % of full scale at 77 °F (25 °C) for thermocouple T - 200...0 °C +/- 0.4 % of full scale at 77 °F (25 °C) for thermocouple N - 200...0 °C +/- 0.1 % of full scale at 77 °F (25 °C) for analogue input voltage/current +/- 0.1 % of full scale at 77 °F (25 °C) for thermocouple C 0...2315 °C +/- 0.1 % of full scale at 77 °F (25 °C) for Pt 100/Pt 1000, Ni 100/ Ni 1000 temperature probe +/- 0.1 % of full scale at 77 °F (25 °C) for thermocouple R, S 200...1760 °C +/- 0.1 % of full scale at 77 °F (25 °C) for thermocouple B 300...1820 °C +/- 0.1 % of full scale at 77 °F (25 °C) for thermocouple K 0...1300 °C +/- 0.1 % of full scale at 77 °F (25 °C) for thermocouple J 0...1000 °C +/- 0.1 % of full scale at 77 °F (25 °C) for thermocouple E 0...800 °C +/- 0.1 % of full scale at 77 °F (25 °C) for thermocouple T 0...400 °C +/- 0.1 % of full scale at 77 °F (25 °C) for thermocouple N 0...1300 °C +/- 0.1 % of full scale at 77 °F (25 °C) for analogue output voltage/current
Temperature Drift	+/- 0.006 %FS/°C
Repeat Accuracy	+/-0.5 %FS input +/- 0.4 %FS output
Non-Linearity	+/- 0.01 %FS analog output +/- 0.1 %FS analog input
Output Ripple	20 mV
Cross Talk	<= 1 LSB
[Us] Rated Supply Voltage	24 V DC
Supply Voltage Limits	20.4...28.8 V
Type Of Cable	Twisted shielded pairs cable <98.43 ft (30 m) input/output
Current Consumption	55 mA 24 V DC via external supply no load 55 mA 5 V DC via bus connector no load 60 mA 5 V DC via bus connector full load 80 mA 24 V DC via external supply full load
Local Signalling	PWR 1 LED green)
Electrical Connection	11 x 2.5 mm ² removable spring terminal block pitch 5.08 mm for inputs, outputs and supply
Insulation	Between input and supply 1500 V AC Between input and internal logic 500 V AC Between output and supply 1500 V AC Between output and internal logic 500 V AC
Marking	CE

Surge Withstand	1 kV power supply common mode IEC 61000-4-5 0.5 kV power supply differential mode IEC 61000-4-5 1 kV I/O common mode IEC 61000-4-5 0.5 kV I/O differential mode IEC 61000-4-5
Mounting Support	Top hat type TH35-15 rail IEC 60715 Top hat type TH35-7.5 rail IEC 60715 plate or panel with fixing kit
Height	3.54 in (90 mm)
Depth	2.76 in (70 mm)
Width	0.93 in (23.6 mm)
Net Weight	0.22 lb(US) (0.1 kg)

Environment

Standards	IEC 61131-2
Product Certifications	CE UKCA RCM EAC cULus cULus HazLoc
Resistance To Electrostatic Discharge	8 kV in air IEC 61000-4-2 4 kV on contact IEC 61000-4-2
Resistance To Electromagnetic Fields	9.14 V/yd (10 V/m) 80 MHz...1 GHz IEC 61000-4-3 2.74 V/yd (3 V/m) 1.4 GHz...2 GHz IEC 61000-4-3 0.91 V/yd (1 V/m) 2 GHz...3 GHz IEC 61000-4-3
Resistance To Magnetic Fields	98.43 A/ft (30 A/m) IEC 61000-4-8
Resistance To Fast Transients	1 kV IEC 61000-4-4 I/O)
Resistance To Conducted Disturbances	10 V 0.15...80 MHz IEC 61000-4-6 3 V spot frequency (2, 3, 4, 6.2, 8.2, 12.6, 16.5, 18.8, 22, 25 MHz) Marine specification (LR, ABS, DNV, GL)
Electromagnetic Emission	Radiated emissions 40 dB μ V/m QP class A 10 m)30...230 MHz IEC 55011 Radiated emissions 47 dB μ V/m QP class A 10 m)230...1000 MHz IEC 55011
Immunity To Microbreaks	10 ms
Ambient Air Temperature For Operation	14...131 °F (-10...55 °C) horizontal installation 14...95 °F (-10...35 °C) vertical installation
Ambient Air Temperature For Storage	-13...158 °F (-25...70 °C)
Relative Humidity	10...95 %, without condensation in operation) 10...95 %, without condensation in storage)
Ip Degree Of Protection	IP20
Pollution Degree	2
Operating Altitude	0...2000 m
Storage Altitude	0.00...9842.52 ft (0...3000 m)
Vibration Resistance	3.5 mm 5...8.4 Hz DIN rail 3 gn 8.4...150 Hz DIN rail
Shock Resistance	15 gn 11 ms

Packing Units

Unit Type Of Package 1	PCE
Number Of Units In Package 1	1
Package 1 Height	3.00 in (7.62 cm)

Package 1 Width	4.30 in (10.92 cm)
Package 1 Length	5.30 in (13.46 cm)
Package 1 Weight	7.05 oz (200 g)
Unit Type Of Package 2	S02
Number Of Units In Package 2	9
Package 2 Height	5.91 in (15 cm)
Package 2 Width	11.81 in (30 cm)
Package 2 Length	15.75 in (40 cm)
Package 2 Weight	5.07 lb(US) (2.3 kg)
Unit Type Of Package 3	P06
Number Of Units In Package 3	144
Package 3 Height	29.53 in (75 cm)
Package 3 Width	15.75 in (40 cm)
Package 3 Length	31.50 in (80 cm)
Package 3 Weight	61.46 lb(US) (27.88 kg)

Sustainability

Green Premium™ label is Schneider Electric's commitment to delivering products with best-in-class environmental performance. Green Premium promises compliance with the latest regulations, transparency on environmental impacts, as well as circular and low-CO₂ products.

Guide to assessing product sustainability is a white paper that clarifies global eco-label standards and how to interpret environmental declarations.

[Learn more about Green Premium >](#)

[Guide to assess a product's sustainability >](#)



Transparency RoHS/REACH

Well-being performance

Toxic Heavy Metal Free

Mercury Free

Rohs Exemption Information Yes

Pvc Free

Certifications & Standards

Reach Regulation

[REACH Declaration](#)

Eu Rohs Directive

Pro-active compliance (Product out of EU RoHS legal scope)

[EU RoHS Declaration](#)

China Rohs Regulation

[China RoHS declaration](#)

Environmental Disclosure

[Product Environmental Profile](#)

Weee

The product must be disposed on European Union markets following specific waste collection and never end up in rubbish bins

Circularity Profile

[End of Life Information](#)

Dimensions Drawings

Dimensions

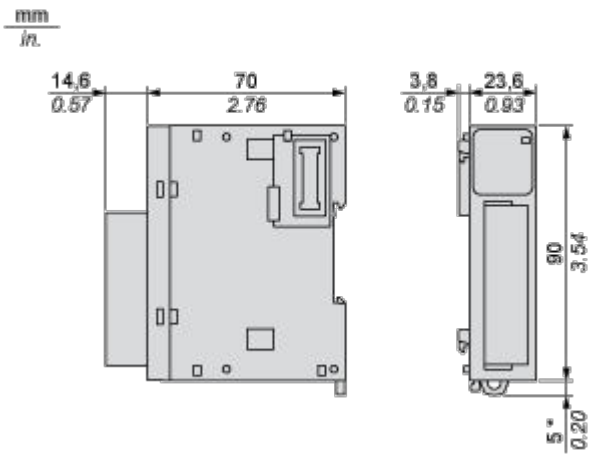

(*) 8.5 mm/0.33 in when the clamp is pulled out.

Mounting and Clearance

Spacing Requirements

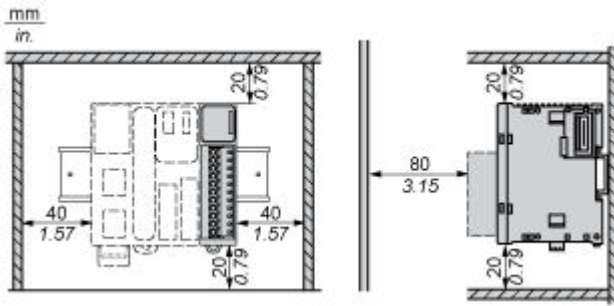

Mounting on a Rail

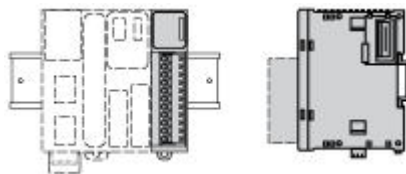

Incorrect Mounting

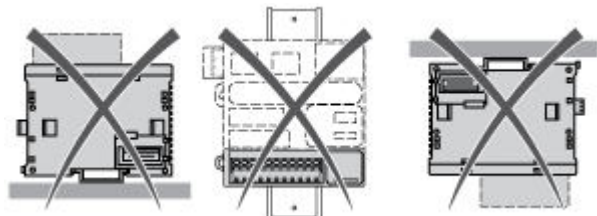

Mounting on a Panel Surface

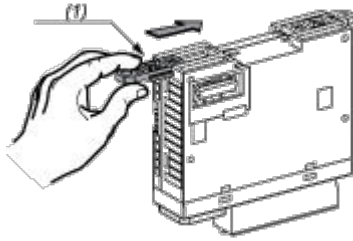

- (1) Install a mounting strip

Mounting Hole Layout

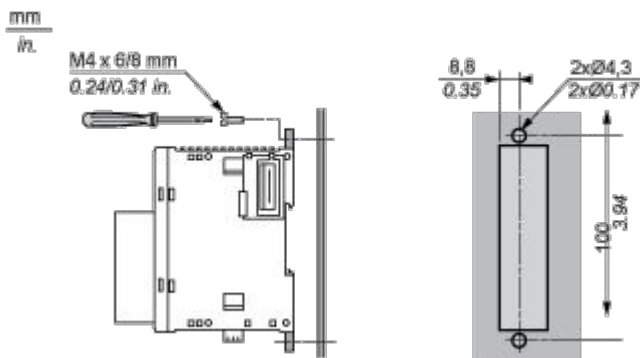

Connections and Schema

Analogue Mixed I/O Module

Wiring Diagram (Current/Voltage type)

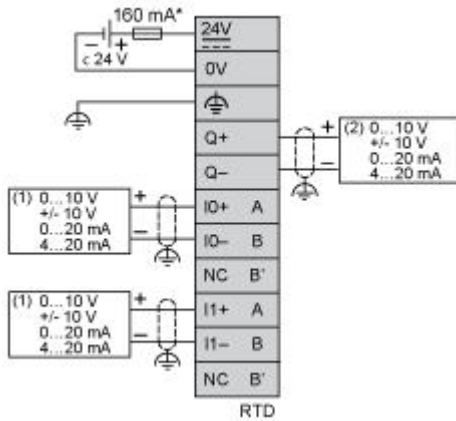

- (*) Type T fuse
- (1) Current/Voltage analog output device
- (2) Current/Voltage analog input device

Wiring Diagram (Thermocouple input type)

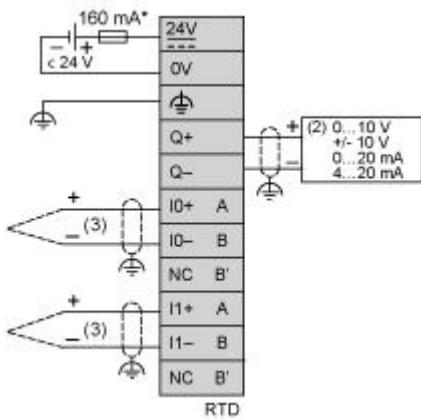

- (*) Type T fuse
- (2) Current/Voltage analog input device
- (3) Thermocouple

Wiring Diagram (Temperature probe input type)

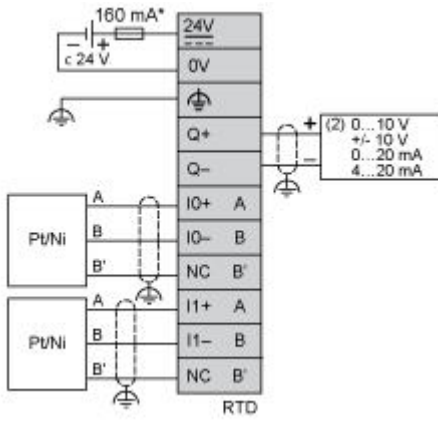

- (*) Type T fuse
- (2) Current/Voltage analog input device